

Liqui-Cel® Membrane Contactors Improve Water Quality and EDI Performance

Electrodeionization

Electrodeionization (EDI) is a widely used water treatment process. EDI technology is an electrochemical process that uses ion selective membranes and an electrical current to continuously remove ions from water. The process uses ion exchange resin to remove the ions from the feed stream, producing pure water. A DC current continuously regenerates the resin.

This technology operates under the same principles as conventional ion exchange resin technology with the added benefit of being a continuous process free of regeneration chemicals.

EDI Feed Water Requirements

In order to maximize the performance of an EDI unit, proper pretreatment is required. EDI equipment suppliers have different guidelines regarding feed water requirements but generally the specification can be summarized on the chart to the right.

Carbon Dioxide and Conductivity

When ion exchange is used to polish reverse osmosis membrane (RO) permeate, CO₂ needs to be controlled. This is true for conventional mixed bed ion exchange and EDI technologies. Excessive CO₂ is the leading cause of an EDI system not meeting design specifications. CO₂ gas dissociates in water to form HCO₃⁻ and CO₃²⁻. These ionic species will contribute to the total anionic load and should be added to the measured total. Overloading the anionic capacity of the EDI unit will lead to higher product conductivity and higher levels of weakly charged ions like boron and silica in the product water.

Feed water conductivity does not show a complete picture of the total ionic load in a water system. Conductivity measurement devices do not detect the full amount of weakly ionized species like carbon dioxide and silica. Suppliers have developed methods to quantify the total ionic load on the EDI system. Two methods are described below:

Equation 1

TEA as ppm CaCO₃ (Total exchangeable Ion) = TDS (ppm as CaCO₃, based on ionized species minus HCO₃⁻) + (ppm CO₂ * 1.14 * 1.7) + (ppm HCO₃⁻ as CaCO₃ * 1.7)

Equation 2

FCE as US/cm (Feed water Conductivity Equivalent) = (conductivity + ppm CO₂ * 2.66 + ppm SiO₂ * 1.94)

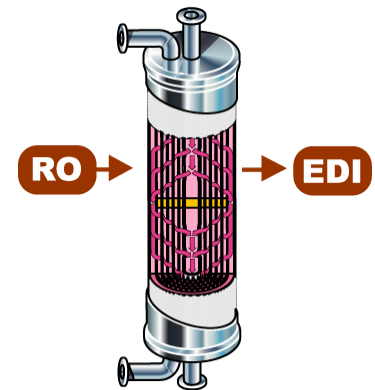

Typical EDI feed water specification

Feed water Constituent	EDI Feed Limit
PH	5-9
Conductivity (uS/cm)	<20
Hardness (as ppm CaCO3)	<1.0
TOC (ppm)	<0.5
Oxidizers (ppm)	ND
Metals (ppm)	<0.01 Fe, Mn
Silica (ppm)	<1.0
CO2 (ppm)	<5.0

EDI Feed Water Specification – Ionic Loading

Feed water Constituent	EDI Feed Limit
Total exchangeable Ion - TEA (as CaCO3) (eq1)	<25
Feed water conductivity Equivalent - FCE (US/cm) (eq2)	<20

These calculations show that the inlet CO₂ will contribute a significant anionic load on the EDI system. For example if the inlet water contains 5 ppm CO₂ and 1.5 ppm bicarbonate (HCO₃⁻) as CaCO₃ this will add 12.24 ppm as CaCO₃ to the TEA and 13.3 Us/cm to the FCE.

The most economical way to lower the load on the EDI is to remove a portion of the CO₂. This is illustrated below.

Anionic Load	5 ppm CO ₂ / 1.5 ppm HCO ₃	1 ppm CO ₂ / 1.0 ppm HCO ₃
TEA as CaCO ₃	12.2	3.6
FCE as Us/cm	13.3	2.66

EDI Pretreatment

EDI feed water pre-treatment is typically made up of softening and filtration using an RO system. These technologies can effectively remove particles, TOC, ions, and dissolved minerals from the water. Dissolved gases, however, are not effectively removed with these technologies.

Membrane Contactors

Liqui-Cel® Membrane Contactors are widely used to remove dissolved gas from water. Membrane Contactors are hydrophobic membranes that allow a gas and a liquid to contact each other without mixing. By adjusting the pressure and concentration of the gas in contact with the liquid, dissolved gasses can be removed from water. A typical membrane contactor system designed for CO₂ removal flows water on one side of the membrane; room air is drawn into the device under a vacuum on the other side. A schematic is shown to the right.

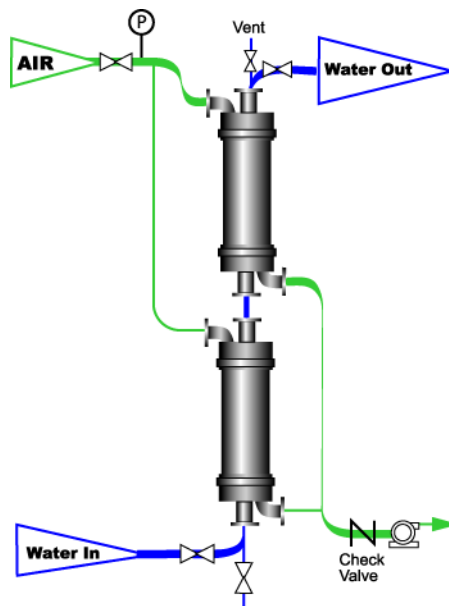

Membrane Contactors operate in-line under pressure and do not require surge tanks or transfer pumps. They can be installed downstream of the RO and upstream of the EDI unit to lower the CO₂ level to 1-5 ppm.

The Membrane Contactor system can be designed to lower the dissolved CO₂ to virtually any level required by the system. Additionally, as the ionic load is decreased, the power consumption of the EDI system can be reduced thus lowering the EDI operating costs. Furthermore, lowering the anionic load will improve the removal of the weakly charged anions like silica and boron.

Summary

Membrane Contactors are an important pretreatment process to an EDI unit. CO₂ can add significant ionic load to the EDI. Membrane Contactors are compact, effective devices for removing the dissolved CO₂ gas in the feed water to protect the unit from being overloaded with anions.

These two membrane-based technologies are leading the way for a cleaner, more environmentally friendly process for producing purified water.

For more information on using Liqui-Cel Membrane Contactors in your application, please visit us on-line at www.liqui-cel.com or call us at the numbers listed below.

References:

Michael Snow, Ph.D., VP, COO, Electropure Inc.
David F. Tessier, Ph.D, R&D Manager, E-Cell Corporation (a GE Business)

Technical Information: The technical information, recommendations and other statements contained in this document are based upon tests or experience that 3M believes are reliable, but the accuracy or completeness of such information is not guaranteed.

Product Use: Many factors beyond 3M's control and uniquely within user's knowledge and control can affect the use and performance of a 3M product in a particular application. Given the variety of factors that can affect the use and performance of a 3M product, user is solely responsible for evaluating the 3M product and determining whether it is fit for a particular purpose and suitable for user's method of application.

Warranty, Limited Remedy, and Disclaimer: Unless an additional warranty is specifically stated on the applicable 3M product packaging or product literature, 3M warrants that each 3M product meets the applicable 3M product specification at the time 3M ships the product. 3M MAKES NO OTHER WARRANTIES OR CONDITIONS, EXPRESS OR IMPLIED, INCLUDING, BUT NOT LIMITED TO, ANY IMPLIED WARRANTY OR CONDITION OF MERCHANTABILITY OR FITNESS FOR A PARTICULAR PURPOSE OR ANY IMPLIED WARRANTY OR CONDITION ARISING OUT OF A COURSE OF DEALING, CUSTOM OR USAGE OF TRADE. If the 3M product does not conform to this warranty, then the sole and exclusive remedy is, at 3M's option, replacement of the 3M product or refund of the purchase price.

Limitation of Liability: Except where prohibited by law, 3M will not be liable for any loss or damage arising from the 3M product, whether direct, indirect, special, incidental or consequential, regardless of the legal theory asserted, including warranty, contract, negligence or strict liability.

Please recycle. Printed in U.S.A. 3M, Membrana and Liqui-Cel are trademarks of 3M Company. © 2015 3M Company. All rights reserved. (TB46 Rev1)



ISO 9001
ISO 14001



**Industrial Business Group
Membranes Business Unit**
13840 South Lakes Drive
Charlotte, North Carolina 28273
USA

Phone: +1 704 587 8888
Fax: +1 704 587 8610

**3M Deutschland GmbH
Membranes Business Unit**
Öhder Straße 28
42289 Wuppertal
Germany

Phone: +49 202 6099 - 658
Fax: +49 202 6099 - 750

**3M Japan Ltd.
Membranes Business Unit**
6-7-29, Kita-Shinagawa,
Shinagawa-ku, Tokyo | 141-8684
Japan

Phone: +81 3 6409 5732
Fax: +81 3 6409 5827



www.liqui-cel.com